

M.2_B_KEY 3042/3052 for LTE+GPS Module

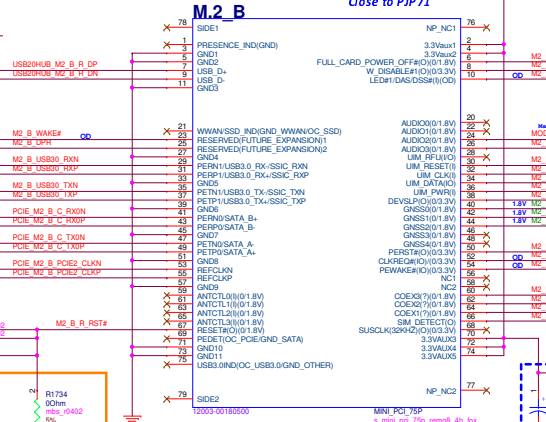

Moude Internal PU:
Pin 8, 26-1.8V/100k
Pin 26- 1.8V/100k
Pin 25, 67-1.8V

Moude Internal PD:
Pin 6-100K

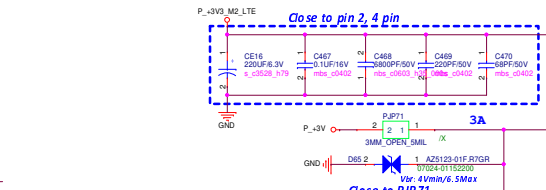
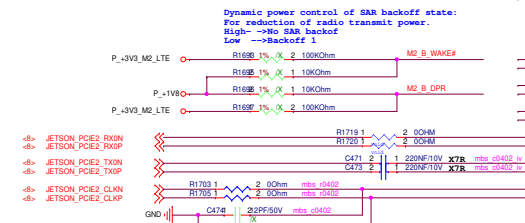
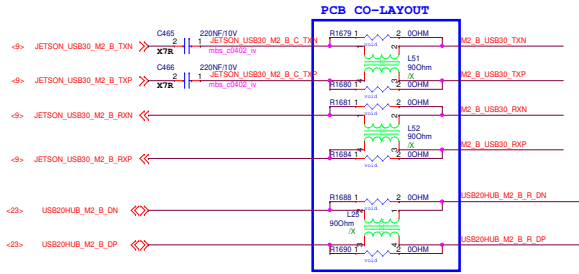
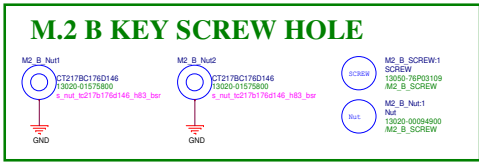